

SNAP-IN REFLECTOR INSTALLATION AND REMOVAL INSTRUCTIONS

TO INSTALL REFLECTOR:

ALIGN ONE END WITH TABS AND SLIDE SLOTS INTO TABS. ON THE OTHER END OF THE REFLECTOR INSERT REFLECTOR INTO CENTER MOST TAB. FLEX REFLECTOR AND INSERT REFLECTOR INTO OUTER TAB (SEE FIG.1).

TO REMOVE REFLECTOR:

REMOVE REFLECTOR FROM EXTERIOR TAB BY FLEXING REFLECTOR (SEE FIG.1). SLIDE REFLECTOR FROM CENTER MOST TAB AND SLIDE OUT OTHER SIDE.

A CURVED TOOL, LIKE A 90 DEGREE SCREW DRIVER,
MAY BE NEEDED TO FLEX REFLECTOR
(DO NOT USE UNPROTECTED FINGER DUE TO SHARP EDGES)

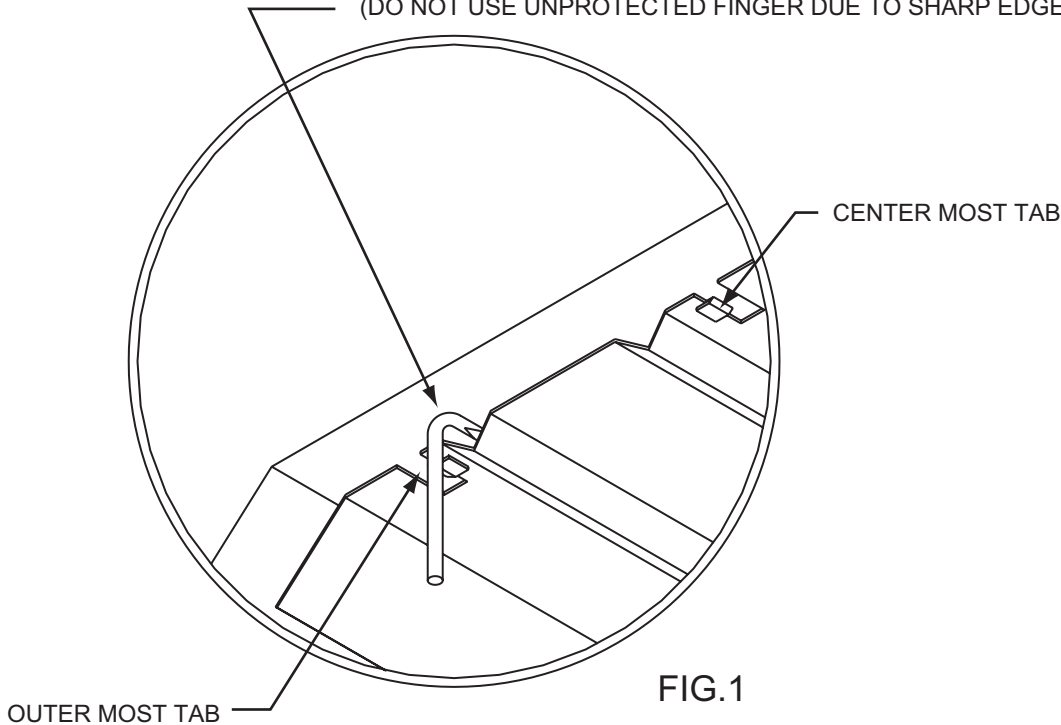

NOTE: WHEN FLEXING REFLECTOR TAKE CARE NOT TO DISTORT REFLECTOR.

NOTE

All fixtures must be installed,
wired and grounded in accordance
with the National Electric Code and all
other applicable codes.

!!! WARNING !!!

RISK OF FIRE OR ELECTRICAL SHOCK. ELECTRICAL
PARTS MAY BE DAMAGED WHEN DRILLING OR USING
"TEK" SCREWS FOR INSTALLATION OF MOUNTING
HARDWARE. CHECK ENCLOSED WIRING AND
COMPONENTS. USE CAUTION WHEN DRILLING "TEK"
SCREWS INTO A BLIND AREA. TO PREVENT WIRING
DAMAGE DO NOT EXPOSE WIRING TO SHARP EDGES.

