

SERIES R455

1 x 4, 1 x 8
Industrial Retrofit Assembly
T5 Technology

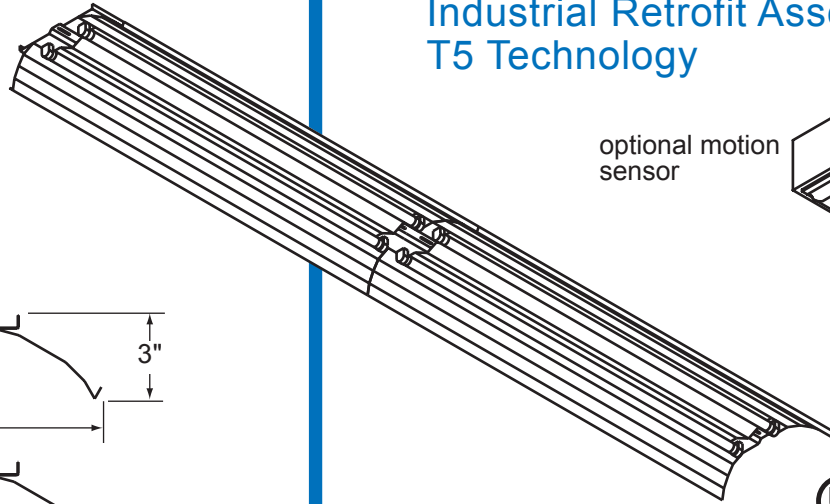

optional motion
sensor

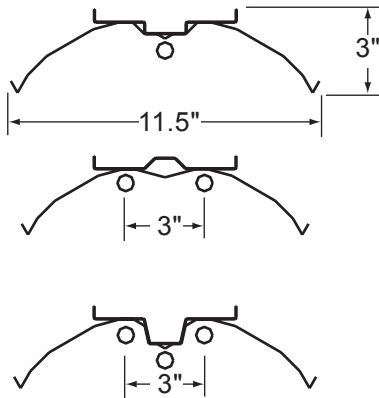

UNION MADE IN THE USA.

ORDERING:

| NOMINAL SIZE | LAMPS | CATALOG NUMBER |
|--------------|--------|--------------------|
| 1' X 4' | 1-FP54 | R455-* -148T5-HO |
| 1' X 4' | 2-FP54 | R455-* -248T5-HO |
| 1' X 8' | 2-FP54 | R455-* -148-2T5-HO |
| 1' X 4' | 3-FP54 | R455-* -348T5-HO |
| 1' X 8' | 4-FP54 | R455-* -248-2T5-HO |
| 1' X 8' | 6-FP54 | R455-* -348-2T5-HO |

INSERT VOLTAGE AT END OF CATALOG NUMBER

FEATURES:

- SNAP-IN LAMPHOLDERS FOR EASE OF INSTALLATION
 - CONVERTS EXISTING INDUSTRIAL OR STRIP FIXTURES TO T5HO TECHNOLOGY TO MAINTAIN A HIGHER PERCENT OF RATED LUMENS
 - PRE-WIRED UNITIZED ASSEMBLY FOR EASE OF INSTALLATION
 - INDUSTRIAL REFLECTOR ATTACHES TO RETROFIT ASSEMBLY TO INCREASE FOOTCANDLES TO THE TASK
 - POST PAINTED HIGH REFLECTANCE POWDER COAT FINISH
- OR
- MIRO 4 HIGH REFLECTANCE FINISH

NOTES:

1. * PK DESIGNATES POWDER COAT FINISH OR
SR DESIGNATES MIRO 4 FINISH
2. FITS EXISTING CHANNEL WIDTH UP TO 5 3/8 INCHES (STANDARD SIZE) AVAILABLE IN VARYING WIDTHS - MEASUREMENT OF EXISTING CHANNEL IS REQUIRED FOR PROPER FIT OF LARGER SIZES
3. CAN ACCOMMODATE EXISTING FIXTURES UP TO 11" WIDE
4. FACTORY INSTALLED MOTION SENSOR OPTIONAL

MANUFACTURING
1715 KIBBY ROAD - MERCED - CALIFORNIA - 95340
(209) 723-9120 - FAX: (209) 723-9131

SALES OFFICE
14722 WICKS BLVD. - SAN LEANDRO - CALIFORNIA - 94577-6718
(510) 667-6950 - FAX: (510) 667-6959

INSTALLATION INSTRUCTIONS

THE WELLMADE RETRO-KIT SERIES OF PRODUCT WILL RETROFIT ALL STRIP AND INDUSTRIAL FIXTURES OF ALL USA MANUFACTURERS WHOSE BALLAST HOUSINGS ARE BETWEEN 3.5" AND 5.25" WIDE.

INSTALLER TO INSURE THAT VOLTAGE OF RETROFIT ASSEMBLY TO BE INSTALLED IS THE SAME VOLTAGE AS THE UNIT TO BE RETROFITTED.

INSTALLER TO INSURE THAT THE WIDTH OF THE EXISTING HOUSING IS LESS THAN THE WIDTH OF THE MOUNTING SURFACE OF THE KIT. IF THE EXISTING HOUSING IS WIDER THAN THE RETROFLECTOR ASSEMBLY, CONTACT WELLMADE REPRESENTATIVES FOR CLARIFICATION.

TO BEGIN THE RETROFIT PROCEDURE:

TURN OFF POWER TO FIXTURE BEING RETROFITTED.

REMOVE EXISTING LAMPS.

REMOVE EXISTING BALLAST/WIREWAY COVER(S).

CUT BALLAST BLACK & WHITE LEADS WITHIN 6 TO 8 INCHES OF BRANCH CIRCUIT CONDUCTORS.

REMOVE EXISTING LAMP HOLDERS FROM SOCKET PLATES, LEAVE SOCKET PLATES IN FIXTURE HOUSING, THEY WILL BE NEEDED.

REMOVE BALLAST. DISPOSE OF IN ACCORDANCE WITH LOCAL CODES AND/OR HAZARDOUS MATERIAL REQUIREMENTS. AT THIS POINT, THE SERIES R455 RETROSTRIP ASSEMBLY IS READY TO INSTALL ON THE STRIPPED-DOWN HOUSING.

INSTALL 1/2" X 1/2" ANGLES IN THE TOP OF CHANNEL APPROXIMATELY 20" FROM EACH END OF THE HOUSING WITH TEC SCREWS. HANG RETROFITTED ASSEMBLY FROM ANGLES BY "S" HOOKS ON SAFETY CABLES. ATTACH GROUNDING WIRE TO THE RETRO- KIT TO THE INSIDE OF THE EXISTING CHANNEL USING THE SELF-DRILLING "TEC" SCREWS PROVIDED. CLOSE "S" HOOKS TO PREVENT THE ASSEMBLY FROM COMING LOOSE.

SNAP THE LAMP HOLDER INTO POSITION IN THE HOLE TO WHICH IT WAS TEMPORARILY ATTACHED AT THE FACTORY.

CONNECT THE POWER SUPPLY WIRES TO THE BLACK AND WHITE LEADS ON THE RETROFIT ASSEMBLY BALLAST WITH WIRE NUTS. CONNECT BLACK WIRE TO BLACK WIRE, AND WHITE WIRE TO THE WHITE WIRE.

TO SECURE THE RETROFIT ASSEMBLY ASSEMBLY TO THE EXISTING HOUSING:

ALIGN THE RETROFIT ASSEMBLY EVENLY WITH THE ENDS TO THE EXISTING HOUSING AND CENTERED FROM SIDE-TO-SIDE.

USING THE "TEC" SCREWS PROVIDED, DRIVE A TEC SCREW THROUGH THE SLOT AT EACH END (AND THROUGH ONE IN THE CENTER) OF THE EXISTING HOUSING SOCKET PLATES. IF PREFERRED, THIS MOUNTING CAN BE DONE BY MARKING A HOLE LOCATION ON THE SOCKET PLATE, USING THE SLOT IN THE RETROFIT ASSEMBLY AS A TEMPLATE, DRILLING A 1/8" DIAMETER HOLE AT EACH END AND THE CENTER, THEN SECURING THE RETROFIT ASSEMBLY WITH #8 SELF TAPPING SHEET METAL SCREW.

INSTALL ONLY T5 LAMPS IN LAMP HOLDERS UNLESS OTHERWISE SPECIFIED. USE OF LAMPS OTHER THAN THOSE SPECIFIED ON BALLAST MAY RESULT IN DAMAGE TO LAMPS OR BALLAST.

TURN ON POWER.

NOTE

All fixtures must be installed, wired and grounded in accordance with the National Electric Code and all other applicable codes.

!!! WARNING !!!

RISK OF FIRE OR ELECTRICAL SHOCK. ELECTRICAL PARTS MAY BE DAMAGED WHEN DRILLING OR USING "TEK" SCREWS FOR INSTALLATION OF MOUNTING HARDWARE. CHECK ENCLOSED WIRING AND COMPONENTS. USE CAUTION WHEN DRILLING "TEK" SCREWS INTO A BLIND AREA. TO PREVENT WIRING DAMAGE DO NOT EXPOSE WIRING TO SHARP EDGES.

